

SHELBY LIFE

MARCH / APRIL 1987

Volume: 12 Number: 2

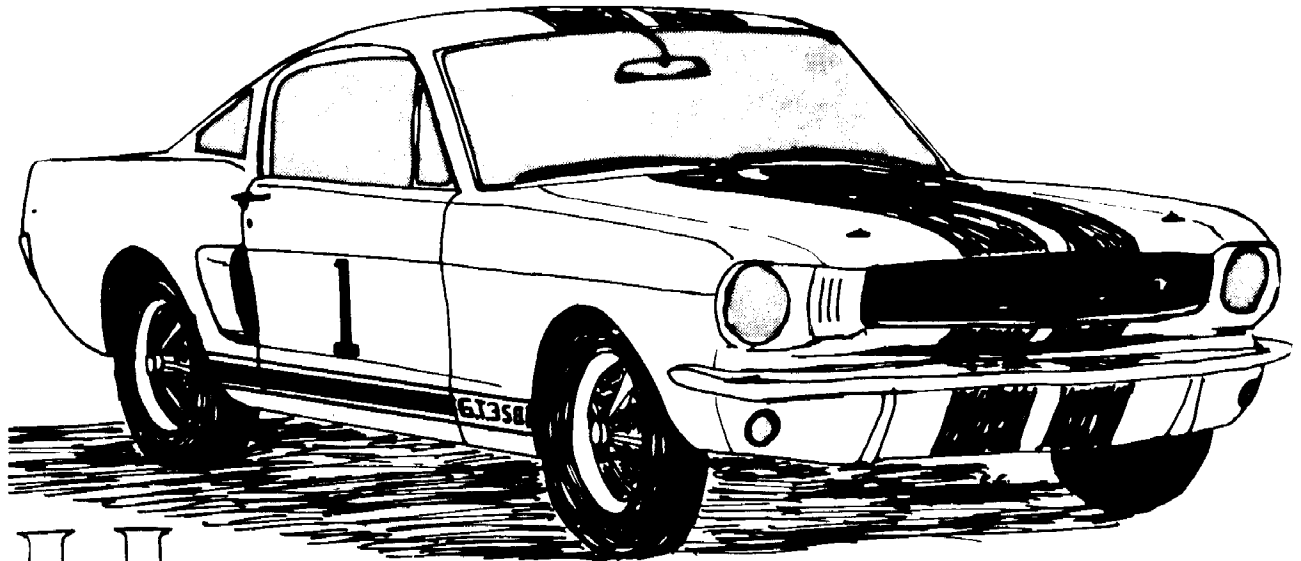

Show and Go XII Need we say More ?





SHELBY AMERICAN AUTOMOBILE CLUB

MOTOR CITY REGION

PRESENTS

SHOW and GO XII

MEMORIAL DAY WEEKEND

MAY 24 & 25, 1987

AAA HEADQUARTERS

Dearborn, Michigan
"Show & Swap Meet"

Waterford Hills Road Course

Waterford Hills, Michigan
"Go"



For further information, contact:

SHELBY AMERICAN AUTOMOBILE CLUB

Motor City Region

P.O. Box 4008

Dearborn, Michigan 48126

COBRA ■ SHELBY ■ TIGER ■ FORD G.T.

Shelby Life

The official publication of the Shelby American Automobile Club's Motor City Region. Opinions expressed in this publication are not necessarily those of the Motor City Region of SAAC, its officials, its members, the publisher or advertisers.

SHELBY AMERICAN AUTOMOBILE CLUB
MOTOR CITY REGION
P.O. Box 4008
Dearborn, MI 48126

1987 Motor City Region Board of Directors

| POSITION | NAME | TELEPHONE |
|----------------------|---------------|----------------|
| Operating Director | Tom Greene | (313) 420-0398 |
| Competition Director | Phil Jacobs | |
| Technical Director | Rich Tweedle | (313) 791-0279 |
| Show and Go Director | Mark Corich | |
| Treasurer | Lee Swonder | |
| Secretary | Dave Allevato | |
| Membership Chairman | John Guyer | (313) 398-7462 |

S.A.A.C. - M.C.R. PUBLISHING
35756 Foothill Drive
Sterling Heights, MI 48077

Editor
Dean V. Ricci
(313) 358-5188 a.m.
(313) 977-0434 p.m.

Circulation
John Guyer
(313) 398-7462 p.m.

TECHNICAL ADVISORS - Tom Ploch
- Clay Stroup
- Mark Sabuda
- Jim Seisser (313) 464-3010
- Mike Reimenschnieder

CONTRIBUTING WRITERS

Thomas Greene
Steve White

SAAC - MCR 1987 Calendar of Events

May 17 All Metro Detroit Area Ford Clubs Joint Exhibition at Hunter's Square Shopping Mall. 420-0398

May 24,25 SAAC - MCR Show and Go XII - All Ford Car Show at AAA Headquarters in Dearborn. Open track event at Waterford Hills Road Course. 420-0398

Sept 20 SAAC - MCR Third Annual Fall Car Show and Swap Meet held at Gorno Ford, Woodhaven, MI. 420-0398

Shelby Life is a bi-monthly publication, with six issues published annually, based on the calendar year. Publication deadline for editorial contributions and/or advertising copy is the first of the month, for publication on the following bi-monthly period.

Advertising Rates

Full Page \$10/per issue
1/2 Page \$ 5/per issue
1/4 Page \$ 2/per issue
Business Card \$ 1/per issue

PIZZA HUT ---->

MEETINGS

Monthly meetings of the Motor City Region are held on the first Thursday of the month at the Pizza Hut on Telegraph, just north of Interstate 96 (Telegraph Exit). Meetings start at 7 p.m. Pizza is \$2/per person.

T
E
L
E
G
R
A
P
H
N
O
R
T
H

1-96

< WEST EAST >

MICHIGAN MEMORIAL WEEKEND

May 24-25, 1987



SUNDAY °° DEARBORN - LARGE CAR SHOW AND SWAP MEET!
MONDAY °° WATERFORD - HIGH SPEED OPEN TRACK EVENT!

CAR SHOW HELD
 RAIN OR SHINE



**SHELBY AMERICAN
 AUTOMOBILE CLUB
 MOTOR CITY REGION**

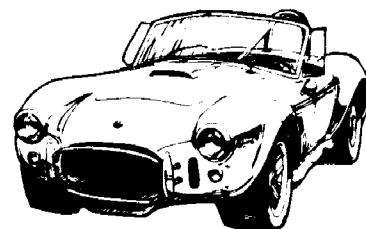

- PRESENTS -

Motor City Show & Go XIII

**** OUR LARGE 12TH ANNUAL ALL "FORD" POWERED CAR SHOW AND SWAP MEET ! ****

MUSTANG, TORINO, PANTERA, TRUCK, COUGAR, BRICKLIN, TRUCK, STREET ROD,
 4 X 4, KIT CAR, YOU NAME IT, IF IT'S FORD POWERED WE HAVE A CLASS FOR IT!

SUNDAY DEARBORN MICHIGAN
 LARGE CAR SHOW!

- EVENT SITE: MICHIGAN AAA HQTS. SOUTHFIELD EXPRESSWAY AT HUBBARD DR. (BETWEEN FORD RD. AND MICHIGAN AVE.) IN DEARBORN MICHIGAN.
- OPEN TO THE PUBLIC AT 9:00 AM.
- GENERAL ADMISSION: ONLY \$2.00!
- CLASSES FOR ALL FORD POWERED VEHICLES!
- NO CLUB AFFILIATION NECESSARY TO ENTER A VEHICLE IN OUR SHOW!
- DASH PLAQUE TO FIRST 250 VEHICLES ENTERED!
- SHOW AND SWAP SET-UP CAN BEGIN AT 7:00 AM.
- CAR SHOW PRE-REGISTRATION: \$8.00, AFTER MAY 15TH: \$10.00. SAAC-MCR MEMBERS RECEIVE \$2.00 DISCOUNT ON THESE REGISTRATION FEES.
- VENDOR SPACES \$15.00 EACH, SIZE: 20'x 20'.

MONDAY WATERFORD MICHIGAN
 OPEN TRACK EVENT!

- EVENT SITE: WATERFORD HILLS ROAD RACE COURSE ON WATERFORD RD. 1/2 MILE NORTH OF DIXIE HIGHWAY (US-10), IN WATERFORD MICHIGAN.
- GATES OPEN TO THE PUBLIC AT 8:00 AM.
- FREE GENERAL ADMISSION AND PLENTY OF FREE PARKING! BRING THE FAMILY AND HAVE A PICNIC!
- SWAP MEET VENDORS FROM CAR SHOW ARE ALLOWED TO SET UP AT THE TRACK AT NO EXTRA CHARGE!
- THE TRACK CONCESSION STAND WILL BE AVAILABLE
- TECH. INSPECTION 8:30 - 10:00 ONLY!
- TRACK OPEN 10:00 AM - 4:00 PM.
- PIT PASSES: \$5.00.
- TRACK FEES: \$20 SAAC-MCR MEMBERS; \$30 FOR NON-MEMBERS. LIMIT 75 CARS. TRACK FEE INCLUDES TWO PIT PASSES. BRING YOUR OWN HELMET!

ALL VEHICLES ENTERED MUST BE FORD OR MERCURY POWERED



FOR ADDITIONAL INFORMATION

| | | |
|------------------------------|--|--------------------------|
| <u>PHONE</u> | | <u>WRITE</u> |
| DOLORES CRAIG (313) 427-4196 | | SAAC - MOTOR CITY REGION |
| TOM GREENE (313) 420-0398 | | P.O. BOX 4008 |
| JOHN GUYER (313) 398-7462 | | DEARBORN, MI 48126 |



COBRA ■ SHELBY ■ TIGER ■ FORD G.T.

Directors Corner

By Tom Greene, MCR Director

For this issue, I thought I'd give everyone a before the fact review of the article which will be published in an upcoming issue of Ford/Mustang Buyers Guide. We will be receiving 500 copies of said publication to pass out at our Show and Go.

SAAC - MCR

We are the Motor City Regional Chapter of the National Shelby American Automobile Club. Our chapter is located in the Detroit area. You've heard of Detroit, that's where most of the cars come from. Because of our proximity to what is still the car capitol of the world, even in the face of what are indeed some fine cars from the land of the rising sun and der father land, we have attracted some of the most devout car freaks in the world.

Our Regional Club was begun by some very ardent Shelby fanatics. The first Motor City Region Show and Go was held BEFORE the first national Shelby Convention was held. The 12th annual event, which will be held on May 24 and 25, 1987, will be our best event yet - but more on that later.

Our club is still comprised of people who all share a common interest, cars in general, (and Shelby's in particular). Perhaps because of the heritage of the Shelby Automobiles, and I refer to the Shelbys built by ole Shel' hisself from 1962 through 1970 here, most of us in the club are also performance oriented. Each of the club events (except for our mid-Winter swap meet) includes an opportunity to let the cars stretch their legs a bit. We have had several events at a high banked oval track where our perennial lead foot award winning driver, Phil Jacobs, has been clocked at 147mph. When we say clocked, we mean speed measured on calibrated radar, not measured by an optimistic speedometer. No, he is not a 427 Cobra driver, he has a 1971 Mach 1 with a "nearly" stock Boss 351. There are several club members who have been close to Phil's speeds, but nobody has beaten him - yet. We have had some other very impressive vehicles competing at our events as well. We have had SCCA prepared Panteras, 289 and 427 Cobras and vintage Boss 302 Trans Am race cars, as well as a myriad of fine Shelbys, Bosses and Mustangs.

We have one rule at any of our events. If you have Ford power, you are welcome to participate. Not to sound contradictory, our club motto is "OWNERSHIP IS NOT REQUIRED, ENTHUSIASM IS". We have members who have those funny plastic cars (you gotta have something to drive in the winter).

Each year, we have an outstanding car show called Show and

Go. We have approximately 50 vendors, 200 cars in the show and OVER 2,000 people coming by to ogle them and to look for parts. This show has attracted some of the best cars in the country. Numbered among our participants are Best of Show popular vote winners and first place concours winners from the National Shelby conventions, as well as cars featured in several national magazines. This glowing description is designed to give you the idea that we have a really good annual event. We do. Our club is a whole lot more than one annual event, though. Our club enjoys more of a family atmosphere than that of a club. We have fun all year long. We have an annual winter swap meet as well as a Fall Car Show and swap meet at the Gorno Ford dealership. The owner of which graciously opens his doors to us for these two events. This dealership owner is a SAAC - MCR member who owns a 1970 GT500 convertible.

As I mentioned before, we are more performance oriented than most other clubs and as such we are usually represented at the local drag strips whenever there is a worthy cause. Like last summer, when the Chevelle Club had an invitational meet at the Milan drag strip. Club members Bob Hoeksma and Mike Reimenschnieder went out there with their Shelbys, a Paxton equipped '66 and a nitrous equipped '68 GT500. They made only 23 runs between them and managed to lose not even one of them. This was not easily accomplished, it required all that the cars and the drivers had to offer. The GT500 ran on street tires through the mufflers to the tune of 12.50 at 119mph. The 289 powered '66 turned 12.82 at 110mph. Mike and Bob made believers in Ford blue power out of those guys who have the distributors in the back. The Chevelle club was blue that day, Ford blue!

And now - the commercial for Show and Go XII. The show and swap meet portion will be held May 24, 1987 at the AAA of Michigan corporate headquarters in Dearborn. The cars and trucks will all be in their finest form. Many of the same vendors we have had in the past will also be in attendance. We are in the same place, at the same time, every year. That way we are easy to find, and we see the same faces looking forward to and showing up at our event every year. A few words about our vendors. I have not known of any of our spectators and participants who were disappointed by the quantity or the quality of the parts to be found at our event. Our vendors range from the guy who was just cleaning out his garage and decided to find out if all that old stuff he had was worth anything, to the big reproduction and specialty suppliers and performance shops from many parts of the country. We have the Ford SVO team and some of their cars show up just to remind the people in attendance that performance is alive and well. Thank you, Ford. In our Show, we have a class for everything from Model T to SVO and everything from concours cars to Pro Street and trucks in between - as long as it is Ford powered. There continued.....

was a 289Hipo (you remember the little engines that sort of clacked at idle) in an Anglia and an XKE at past shows.

The next day, we gather at the Waterford Hills Road Course a few miles to the north. We have the facility for the entire day, and will be running groups of three or four cars at a time on an individually timed, open track event. I saw the vintage races that were held there for the past two years and have vivid memories of the 289 FIA Cobra running away from the pack, then "crusing" to victory ahead of the Grand Sport Corvette. We are all looking forward to trying out a real race track with our somewhat willing but aging cars.

The safety of the participants and the cars is also a major concern of ours. We will have professional corner workers and emergency medical service at the track. The cars will be spaced out so that they will not be running close to each other. The competition will be there. We hope that you are there to watch it. P.S. General admission is free, as is parking. Enough logistics. The main reason for having this event is to have fun and to let the spectators see the cars in action that they saw sitting the day before.

We have a policy in the club to make the events as reasonably priced as possible. To that end, the entry fees we charge are sufficient to cover only the expenses of putting on the event. Because of the time required to tech each car and to make sure that the people who have plunked down their \$30 have the track time that they deserve, we have limited the number of cars which will be allowed to participate in the open track event to 75. First registered, first allowed in. The club director and the competition director have already reserved positions number 1 and 2. Rank does sometimes have its priviledges.

Our club meetings are attended by wives, boy friends, husbands, girl friends (not necessarily in that order) and children, not by a bunch of guys who just sit around and do nothing but bench race. We share information about the cars and solving problems of all types. We also keep up with events and cars for sale. We even go out and look at some of the more interesting cars for sale and bring reports back to the membership. This kind of information is something that you just can't get from magazines. Imagine writing to a magazine and asking them for an opinion before you cash in your life savings and hock the kids to buy the car of your dreams. You can do this at our meetings, as well as getting leads on those hard-to-find parts. We have family outings and parties for the children. We accomplish a lot by cooperating with the other Ford clubs in the area. We pride ourselves in maintaining good relationships so that we may all benefit. If anybody reading this has been a part of running a club before (any club from Cub Scouts to the local Rotary) you know that it is important to maintain interest and good working relationships with EVERYBODY. Our club is all about the people in it and enjoyment of our cars.

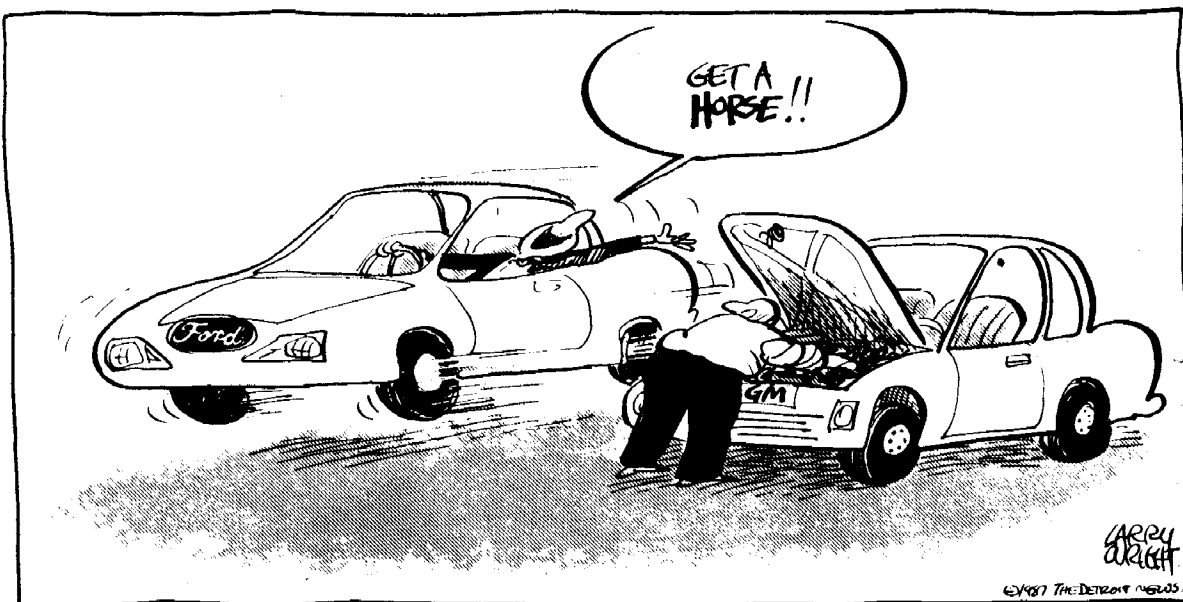
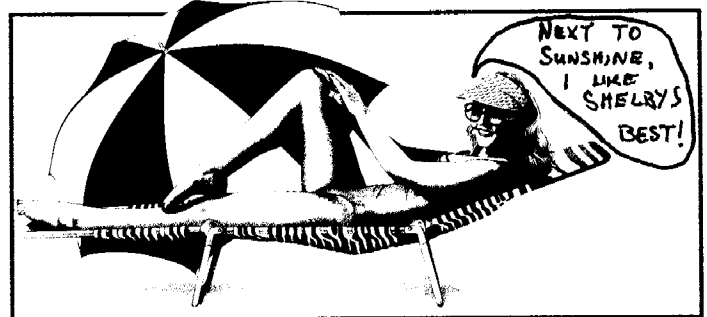

Meeting Minutes

by G.U. Foundit

Minutes of the March 5th Motor City Region assemblage.

The meeting was called to order at 8:00pm, but not before those in attendance had sufficiently consumed the usual mass quantities of pizza, beer, sodas and whatever else was on the menu.

Swap and sell was bantered about, for results of parts that were turned up, look to the classifieds section elsewhere in this issue.

A Financial report was given by Lee Swonder, our Treasurer. The books show our coffers filled with \$3,100. (cough-cough !)

National news was presented by John Hill, who has informed us that SAAC-MCR has a block of 20 rooms at the hotel for the next national convention. This effort was undertaken by John himself and resulted in thundering rounds of applause from the club members in attendance. See related story elsewhere in this issue.

T.L. Greene reported that we have official authorization from AAA for use of their parking lot for "Showing", but not "Going". The club plans to attend the predicted HUGE Hunter's Square mall show for all FORD marque clubs. Show is being

produced by Gary "call me 428" Pietraniec of Mustang Owners Club fame. The event is scheduled for the weekend before Show and Go. The cost of an ambulance on call at WHRRR for \$28 in lieu of on site service cost of \$325 is being debated. Dean Ricci was informed by a WHRRR official that on site service may be madatory. Also we have received verbal confirmation of track rental, but no contracts have been sent for us to sign. (Hmmm...) The other open issue is getting lap timers for the event to work in the timing tower. We also got an offer from Ben Schiewe. He is bringing some of his employees to help at tech. We also got a call from John Vermeersch. He wanted to reserve a spot at the track. The bottom line is that we have generated lots of interest in our event for this year, and with some new people. Our club publication has generated lots of interest in the club as well. Tom Greene sent in an article on the club to Ford/Mustang Buyers Guide at the end of February. **SERMONETTE:** Consider this comment as official castigation for the assembled group. Tom received pictures from only two people (other than those Tom supplied himself). This is not the kind of support Tom has grown to expect from this club. John Guyer was contacted by Four Bears Water Park. We discussed the possibility of having a car display there. Maybe John Guyer will contact them for details. If everything looks good, we will target an event for August.

The usual 50/50 drawing was held, with cash winners and trinket winners. Trinkets were donated by Jim Seisser. The meeting was adjourned shortly thereafter around 9pm. Everyone left in anticipation of returning next month, won't you try and join us ?

THERE'S NOTHING PHYSICALLY WRONG WITH YOUR TOYOTA. IT JUST WISHES IT WAS BORN AS A SHELBY MUSTANG!

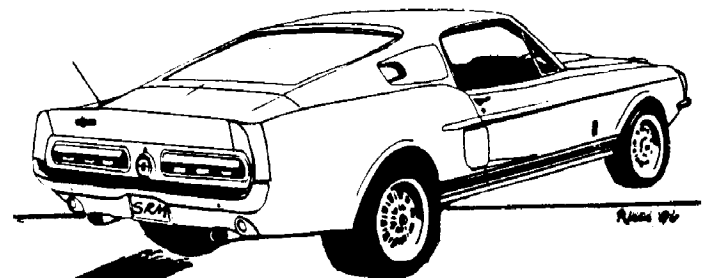
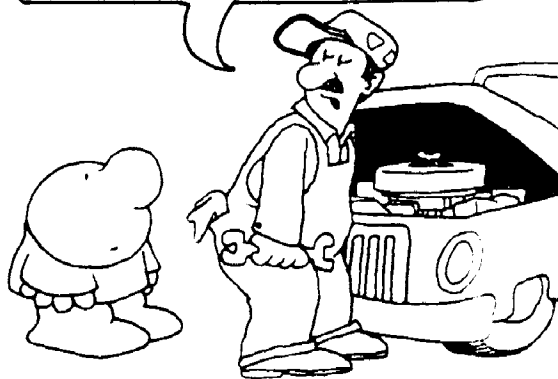

HELBY!

SAAC - XII

This important message is directed to those of you who are planning to attend SAAC 12 in Charlotte, NC.

We are first trying to get an idea of who's doing what. We will make every effort to coordinate activities but in order to do so need to know your plans. There will probably be too many for one convoy but two or three smaller groups could work depending on departure times, etc.

A block of twenty rooms has been reserved for our club at SAAC 12 convention headquarters, Adam's Mark. To be sure that you get one of these choice rooms we are asking that you

complete the information on the form listed below.
Fill out the form NOW and mail it to:

John Hill, SAAC - 12
44801 Oregon Trail
Plymouth, MI 48170

SAAC 12 promises to be the largest convention ever. It's one you wouldn't want to miss. The convention schedule is detailed in the latest issue of SNAKEBITE. For your information, Charlotte is about 750 miles from Detroit, a long days' drive.

OK now, go find a pencil, envelope and a stamp and fill out this here form!

SAAC - 12

RESERVATIONS

Name : _____

Address : _____

City, State Zip : _____

Credit Card Name: _____

Credit Card # : _____ Expiration Date: _____

Phone Numbers : (day) _____ (evening) _____

Number of people in party: _____

Number of rooms: _____ Type of rooms: (single/double) _____

Nights required: (please circle) 7/1 - 7/2 - 7/3 - 7/4

Note: Late arrival will be guaranteed and a no show will cost you !!!

GENERAL INFORMATION

Plan to leave Detroit area (date/time) _____ Driving straight through (yes/no) _____

Towing another vehicle (yes/no) _____ Type of car you're driving _____

Interested in a convoy (yes/no) _____ Planning to return to Detroit (when): _____

Would like to caravan back (yes/no) _____

In order to make the necessary arrangements we need your completed form by May 15, 1987. Let us help you plan a great trip.

S H E L B Y A M E R I C A N A U T O M O B I L E C L U B

Hosted by the Indiana Region
Cooperating: Il, Ky, Mi, Mo, Oh Regions of SAAC and Midwest Region of Tigers East/Alpines East



INDIANA'S

10TH ANNIVERSARY
1977 SHELBY SPRING FLING 1987



BROWN COUNTY STATE PARK
NASHVILLE, INDIANA

MAY 15-17, 1987

FRIDAY Cash Bar
Welcoming Bash
Video Tapes
Shelby Memorabilia
Photo Album Sharing

SATURDAY Parts Swap
Car Show
Judged & Popular Vote
Classes by Pre-registration
Awards Banquet/Program

SUNDAY Paved Roads
Road Rallye
Classes by Pre-reg.
Timed Driving Rallye
And SCCA Autocross

Lodging at the Rustic Abe Martin Lodge in the Park
\$29-36/night. Two nights required (Fri/Sat)
Lodgings available only thru Indiana SAAC

**EARLY REGISTRATIONS
BY APR 15**

Lodge/Cabin Reservations \$29-36 deposit
Road Rallye Pre-entry \$ 4 per car/driver
Early Meet Registration \$16 per couple/car
Western Pig Roast Banquet \$12.50 per person

CONTACT:
INDIANA SAAC
Steve & Joyce Yates
Rt. 1, Box 377
Nashville, IN 47448
(812)988-7146

POWERED
BY
FORD

COBRA ■ SHELBY ■ TIGER ■ FORD GT

Spring Fever (Holley Style)

By Steve White

It hasn't snowed or been below freezing for several weeks now. The three months of road salt has been washed away by the early spring & late winter rain showers. The weather is in the upper fifties and lower sixties for an hour or two each day. The animals and plant life are emerging from their hibernation. But most importantly, a real beast is about to stir from its cave. That beast is your beloved Shelby or Mustang, and the cave is the garage it has been cooped up in to save it from the nasty northern winters.

But when you run out to the garage, heart pounding wildly with anticipation, start up your dream machine, it won't idle even to lowly Chevy standards without rattling your insides or stalling. What the **@! is going on? It ran great last fall when you tucked her in for the long winters nap. Maybe you even went so far as to start the engine and warm it up or even drive it on good days every 2-4 weeks, but the last few

months you succumbed to the winter lazies figuring it would soon be spring and there would be no problem.

Well, if you have a Holley 4-barrel carb (Model 4150 as most Shelby and many hi-po Mustangs came factory equipped or a Model 4150/4160 aftermarket version) that wasn't purchased new, or rebuilt with a Holley kit in the last few years, there is a chance that the metering block to main body gasket has shrunk. You see, Holley had a good idea when originally designing these carbs around the modular concept (separate fuel bowl system, metering system, etc. in individual castings). This is part of what has made them so popular over the years, since they were easy to work on and modify. However, this has also brought with it some drawbacks. The original carbs manufactured ever since the first 4150/4160 rolled off a vehicle assembly line on a '56 Chrysler used a cork gasket between the metering block and main body. Cork was a favorite gasket material for many engine gaskets for many decades. However when exposed to fuel, then allowed to dry out as the aged fuel evaporates and is not replenished over time (such as by periodically starting the engine) the cork gasket shrinks. When the gasket shrinks, several of the numerous passageways between the metering block and main body can be partially blocked by the gasket. If this happens, the engine idles poorly or not at all, and most likely exhibits stumbles or hesitations on driveways.

Fortunately, Holley recognized this, albeit 20+ years late, and developed new gaskets made of a fibrous material that is coated and is either brown or black in color depending upon the gasket supplier. These gaskets do not shrink, and in fact the coating of the gasket when heat cycled bonds itself to the casting. This can make it a real bear to disassemble and often requires a razor blade to scrape off the "old" gasket when working on the carb after it has been thermo-cycled. But that's a small price to pay for more consistent engine operation. In fact, in some cases the gasket comes off cleanly.

There are a number of other typical carb trouble shooting problems possible such as the fuel bowl screws loosening up and allowing a small air leak at idle (due again to the modular design, thermo-cycling, and probably requires the fuel bowl screws and main body tapped holes to be at the extreme of their tolerance limits) and power valve diaphragm failures (usually only occurring after a severe engine backfire which ruptures the diaphragm material). But in cases where the car ran good when it was put away in storage, the gasket being cork and shrinking as being the problem occurs 9 1/2 times out of 10.

So when rebuilding your Holley carb, make sure your new kit does not use cork gaskets (or buy a Brasswell reinforced rubber style gasket) unless you drive your car almost every day, or still want to rebuild your carb frequently.

Just idling along....

Know what's
happening !

Call the
Auto Sport Hotline
884-4178
(recorded message)

Get all the
information on
upcoming Car Club
events

HOLLEY M-4150/4160 METERING PASSAGEWAYS
 SUSCEPTABLE TO MISCOMMUNICATION DUE TO GASKET SHRINKAGE

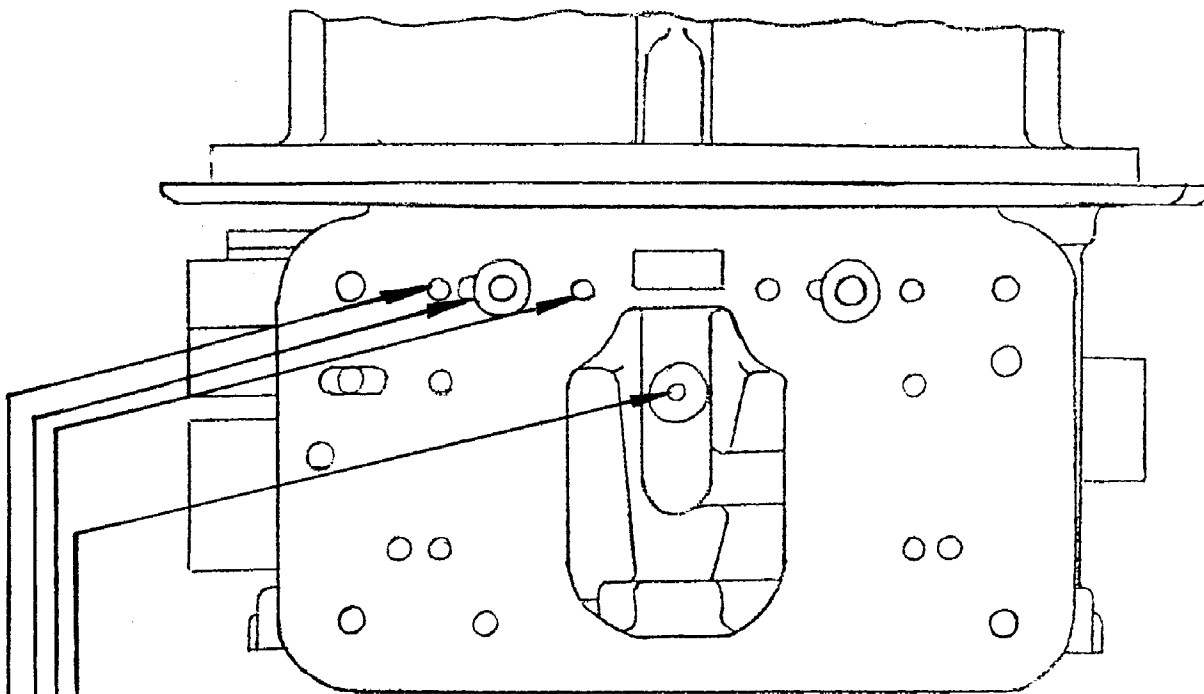

MAIN BODY - METERING BLOCK-TO-MAIN BODY GASKET VIEW

- TO ACCELERATOR PUMP SHOOTER
- TO HIGH SPEED BLEED
- TO NOZZLE DISCHARGE
- TO IDLE AIR BLEED
- TO IDLE TRANSFER SLOT
- TO IDLE DISCHARGE
- TO VACUUM ADVANCE PORTED SIGNAL
- MAIN WELL BLEED

- ALIGNMENT PINS/HOLES
- IDLE DOWN LEG
- FUEL FROM MAIN TO IDLE
- FROM MAIN JET/WELL/TUBE
- POWER VALVE CHANNEL TO NOZZLE
- BLEED WELL-TO-MAIN WELL RESTRICTION
- ANGLE CHANNEL BLEED
- MAIN WELL-TO-IDLE WELL BLEED

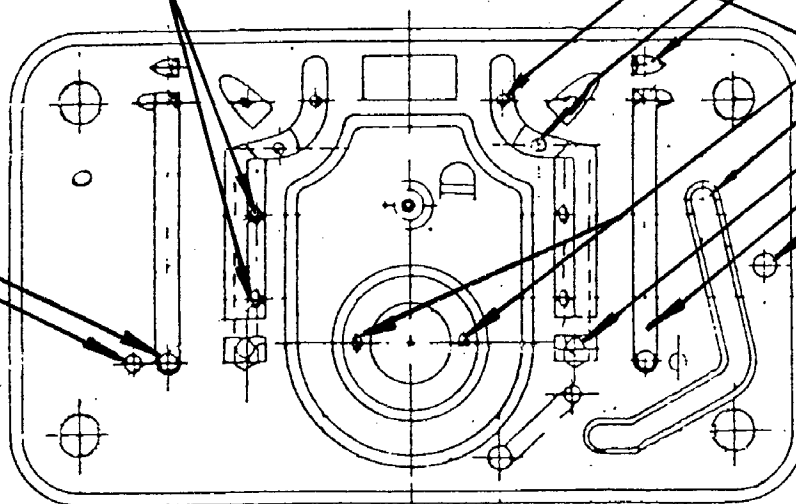

METERING BLOCK - MAIN
 BODY - TO - METERING
 BLOCK GASKET VIEW:
 NOTE THE NUMBER OF
 PASSAGES IN CLOSE
 PROXIMITY TO EACH
 OTHER

HOLLEY M-4150/4160 HYDRO-PNEUMATIC SCHEMATIC

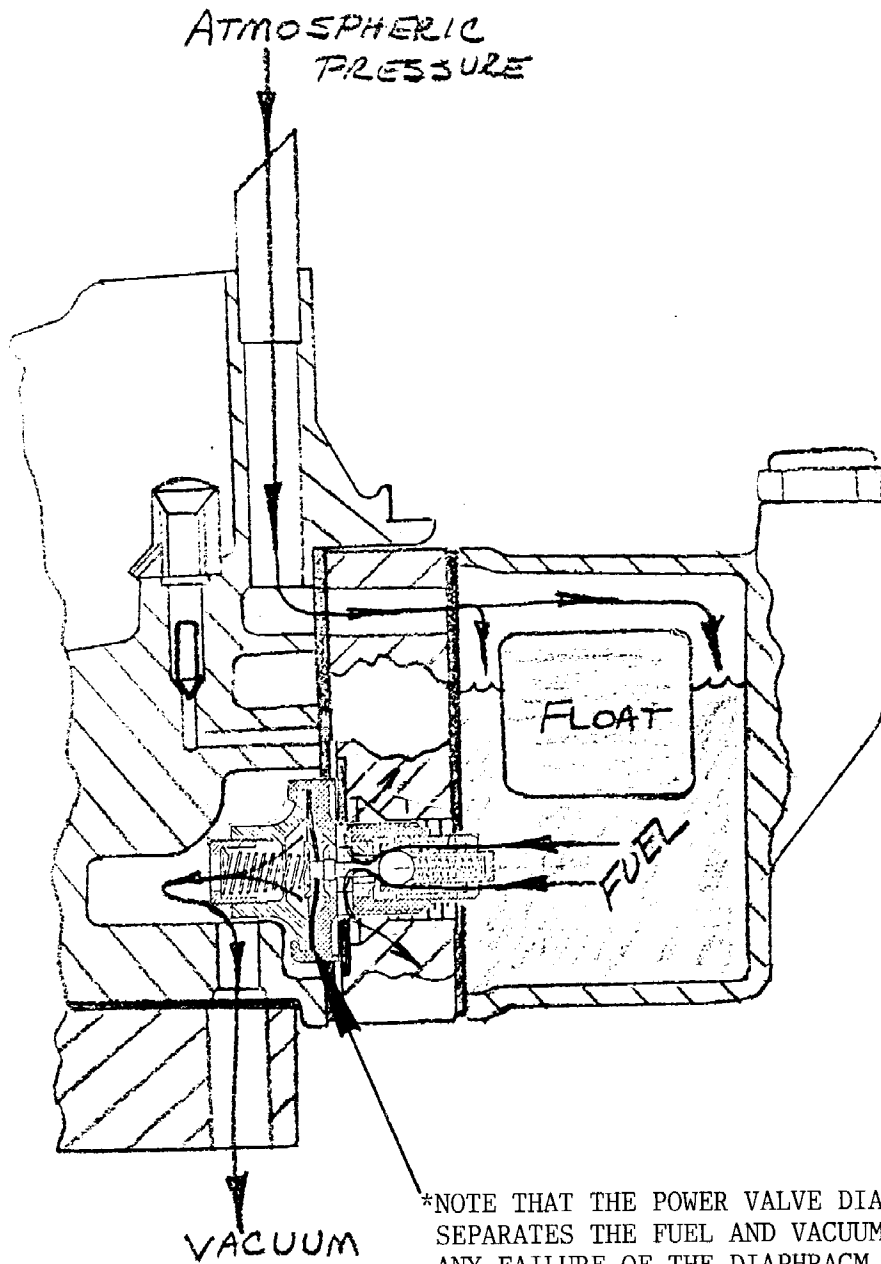

SHELBY AMERICAN AUTOMOBILE CLUB - MOTOR CITY REGION
SHOW 'n GO XII

Registration Form

Names: _____ Address: _____

Telephone: ()- _____

Vehicle: _____ Year: _____ Type: _____ Color: _____

Vehicle: _____ Year: _____ Type: _____ Color: _____

SUNDAY - MAY 24, 1987

THIS EVENT HELD ON THE AAA PARKING LOT IN DEARBORN (SOUTHFIELD AND HUBBARD)

CAR SHOW REGISTRATION

\$8.00 before May 11, 1987

\$10.00 after May 11, 1987

Amount Enclosed _____

CLASSES FOR ALL FORD POWERED VEHICLES. TROPHIES BASED ON PREREGISTRATION.

20 X 20 Swap Spots

\$15.00

Amount Enclosed _____

SAAC - MCR MEMBERS SUBTRACT \$2.00 FROM ONE OF EITHER OF THE ENTRY FEES ABOVE

MONDAY - MAY 25, 1987

OPEN TRACK EVENT AT THE WATERFORD HILLS ROAD RACE COURSE

NO CHARGE TO SPECTATORS -- PIT PASSES \$5.00

Tech Inspection open ONLY Until 10:30. If you're not in line you don't run.

1.5 Mile Track * 75 Car Participation Limit * 3 - 5 Cars on the track at a time

INDIVIDUALLY TIMED EVENT - ABSOLUTELY NO PASSING

\$30.00 non-member

\$20.00 SAAC - MCR member

Amt. Enclosed _____

VEHICLE ENTRY INCLUDES TWO (2) PIT PASSES.

HELMETS AND SEAT BELTS ARE MANDATORY. VEHICLES MUST PASS TECH INSPECTION.

SAAC - MCR MEMBERSHIP DUES

The annual dues are \$12.50. Payment of your dues at Amt. Enclosed _____
this time entitles you to the discounts shown above.

Please fill out this
form completely
and return to:

SAAC - MCR
P.O. BOX 4008
DEARBORN, MI. 48126

TOTAL AMT ENCLOSED _____

For further information, please call Tom Greene 420-0398, Mark Corich 563-5403
Dolores Craig 427-4196, or John Guyer 398-7462.

CLASSIFIEDS

Wanted: (2) 15" Magnum 500 style wheels (such as off a '72 Gran Torino - trim rings not required) Steve 773-9588

Wanted: 1 set of headers for 2bb1 Cleland heads. Jim 581-3483

For Sale: Boss 302 carb 1970 rebuilt \$120. Miscellaneous 500 to 700 cfm Ford and Holley carbs. Boss 351/351HO/351CJ service carb (4300D) manual trans \$80. Mike Riemenschnieder 459-1348

For Sale: '68 390 Mustang Fastback \$2500 or best offer. Kevin 851-1920

For Sale: Hays pressure plate for small block Ford, street/strip version. Wanted: need (2) two high back tilt type bucket seats. Any color is ok. Bob Craig 427-4196

For Sale: 1970 Mustang Mach 1. Good condition, drive train has been removed, but 90% on hand. Priced to sell. Contact Bob Craig 427-4196. No Rust, great project car.

For Sale: '87 Mustang GT tires and wheels \$800 Jim 464-3010

Wanted: 1969 Mustang Mach 1,

have been looking for 8 years for right car. Nyra 665-8320

For Sale: Chrome Engine Dress up Kits - New - for 260, 289, 302, 351W, and sets for 351C, 302, 351W, and sets for 351C, \$30. 351C exhaust manifolds - used - from 1970 4V engine, sand blasted and painted with Eastwoods stainless steel high temp exhaust paint. Best Offer Steve 773-9588



SHELBY AMERICAN AUTOMOBILE CLUB
MOTOR CITY REGION

APPLICATION FOR MEMBERSHIP

Annual Dues \$12.50

Please type or print clearly.

Name _____
 Spouse _____
 Children _____
 (to be used in planning social events)

Address _____
 City _____ State _____ Zip _____
 Phone-Home _____ Work- _____

| Type: | VEHICLES | | | CONDITION | | | Show Quality |
|-------|----------|--------|--------------------------|--------------------------|--------------------------|--------------------------|--------------|
| | Year: | Color: | In Restoration | Fair | Good | | |
| _____ | _____ | _____ | <input type="checkbox"/> | <input type="checkbox"/> | <input type="checkbox"/> | <input type="checkbox"/> | |
| _____ | _____ | _____ | <input type="checkbox"/> | <input type="checkbox"/> | <input type="checkbox"/> | <input type="checkbox"/> | |
| _____ | _____ | _____ | <input type="checkbox"/> | <input type="checkbox"/> | <input type="checkbox"/> | <input type="checkbox"/> | |

What are your interests:

- Autocross Drags Car Shows Social Events Rallies (Non Speed)
 Parts Swap Tech. Seminars Other _____

Are you willing to help with club activities:

- Newsletter, Mailings Planning & Organizing Events Working at Events
 Other _____

Are there other ways in which you may help the club:

Such as parts discounts, trophies, making signs, technical assistance, club jackets, etc.

Mail completed application with check or M.O. for \$12.50 to:
SHELBY AMERICAN AUTOMOBILE CLUB, Motor City Region

P.O. Box 4008
 Dearborn, Michigan 48126

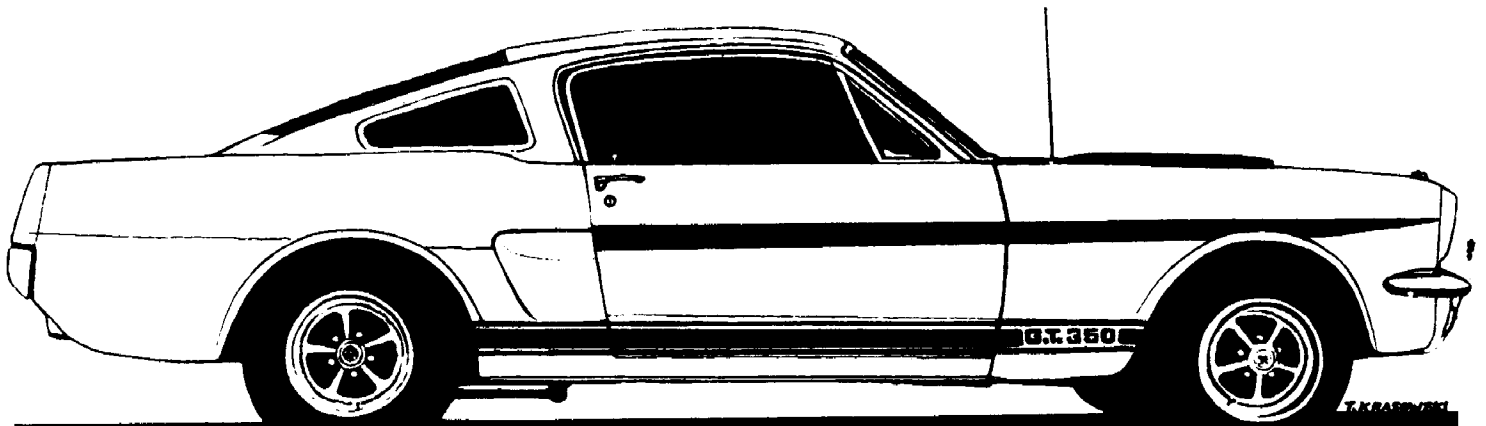

SHELBY G.T. 350

S.A.A.C. - M.C.R. Publishing
35756 Foothill Drive
Sterling Heights, MI 48077

BULK RATE
U.S. Postage
PAID
Royal Oak, MI 48068
PERMIT NUMBER 529

Send To: _____



SHELBY AMERICAN AUTOMOBILE CLUB
MOTOR CITY REGION